

Energy

Automatic labeller

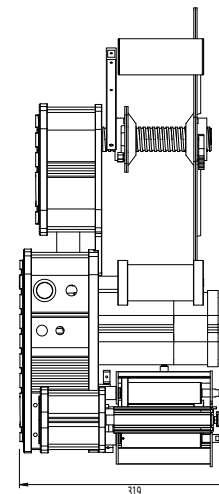

Energy is the automatic labelling machine devised to meet a variety of applications, thanks to a wide range of optional devices available, allowing to configure the machine according to one's specific production needs. It is equipped with an innovative multitasking electronics that, through encoder, manages multiple functions simultaneously. The hybrid stepper motor allows optimal control on label distribution with tolerance range close to zero on stop. The touchscreen allows changing settings even when the machine is running.

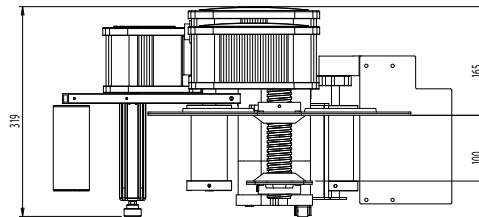
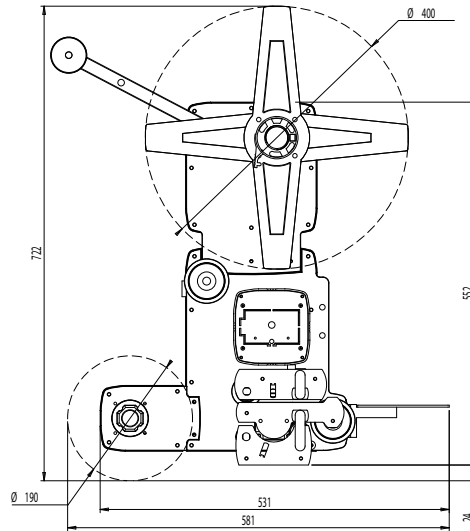

Technical Specifications

	100	200	300
Speed	≤ 60 m/min	≤ 50 m/min	≤ 20 m/min *1
Dispensing W	20-100 mm	20-200 mm	20-300 mm *2
Outside reel Ø	≤ 280 mm - optional 380 mm		
Inside reel Ø	40 - 75 mm		
Motor	Hybrid stepper motor		
Stop Tolerance	± 0,2 mm		
Size L - W - H	581x319 x 722 mm	611x419 x 752 mm	611x578 x 802 mm
Power supply	115/230 V, 50-60 Hz		
Power	150 W		
Electrical protection	IP 55		
Noise level	70 dB		
Version	RH - LH		

*1 with label widths up to 250 mm

*2 motorized rewinder required for labels wider than 250 mm



Etipack reserves the right to modify according to the technical evolution, without notice.
All the rights of intellectual and technological ownership are reserved



Cinisello Balsamo (MI) - Tel. 02 660621 - Fax 02 6174919 - www.etipack.it