

System 1 modular

For wrapping applications



System 1 Modular is an automatic labelling system for wrap-around application on cylindrical jars and bottles: it has been as a modular unit, that can be implemented according to users needs. The basic module can be equipped with any accessory available for the labelling systems, such as print units, controls, alarms, PLCs. All functions are managed through a touch screen panel.

Technical Specifications

	S1 - Energy 100	S1 - Strong 100
Production speed	max 12.000 pcs/hr	max 9.000 pcs/hr
Dispensing speed	max 50 mt/min	max 30 mt/min
Product size	Ø 20 - 80 mm	Ø 20 - 80 mm
Label size length	20 - 240 mm	20 - 240 mm
Label size width	8 - 98 mm	8 - 98 mm
Outside reel diameter	280 mm (380 mm optional)	280 mm
Inside reel diameter	40 - 75 mm	40 - 75 mm
Machine size L-W-H	2580 x 1400 x 1160 mm	2580 x 1400 x 1160 mm
Power supply	220 - 240 V, 50 - 60 Hz	220 - 240 V, 50 - 60 Hz
Electrical input	1300 W	1300 W
Compressed air	6 bar	6 bar

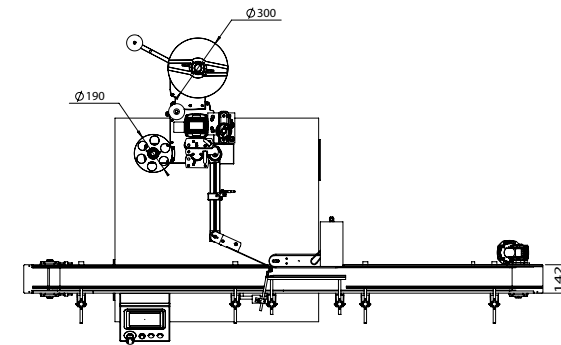
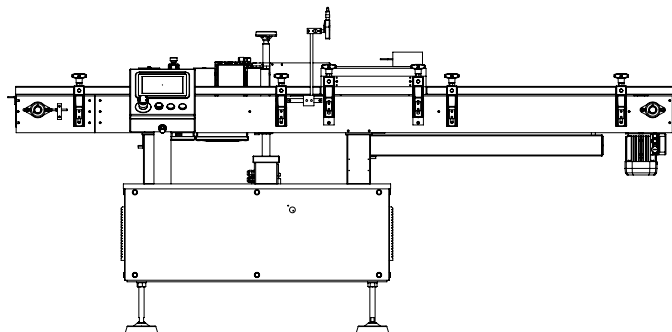
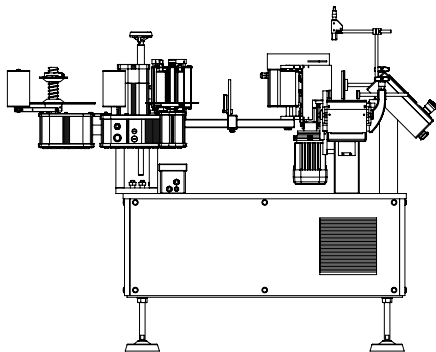

Etipack reserves the right to modify according to the technical evolution, without notice.
All the rights of intellectual and technological ownership are reserved



Cinisello Balsamo (MI) - Tel. 02 660621 - Fax 02 6174919 - www.etipack.it