

System 1 Twist

For wrapping application



A compact and functional solution ensuring a perfect labelling of cylindrical products. The DRP device makes the product spin around during the labelling phase. A very compact body makes it fit for any environment.

Technical Specifications

	System 1 Twist
Production speed	≤ 3000 pcs./h prod. Ø 50 mm
Dispensing speed	≤ 15 mt/min
Product size	Ø 20 - 100 mm
Label size length	8 - 250 mm
Label size width	8 - 98 mm
Outside reel diameter	280 mm
Inside reel diameter	40 - 75 mm
Machine size L-W-H	1587 x 1358 x 1243 mm
Power supply	230 V, 50 - 60 HZ
Electrical input	700 W
Compressed air	6 bar with print units

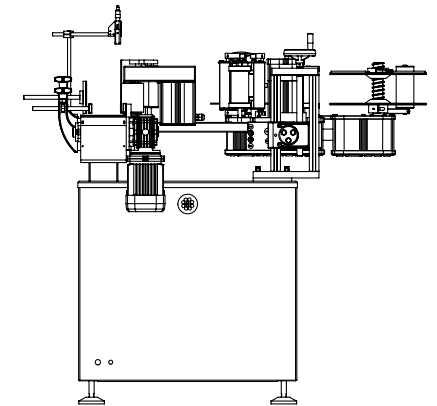
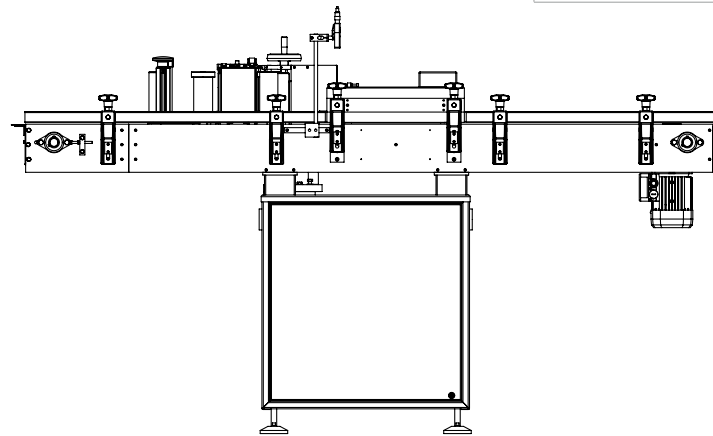
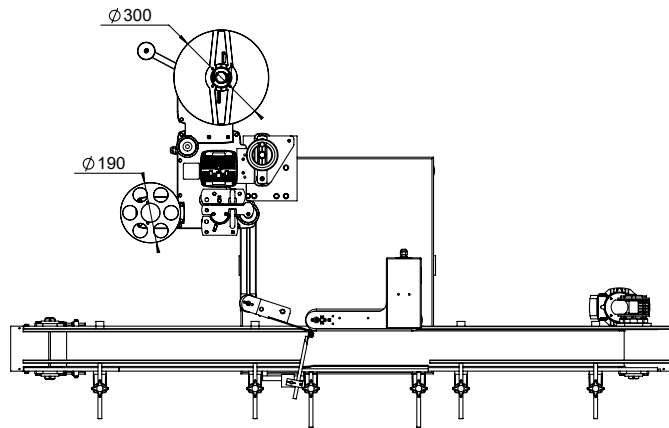

Etipack reserves the right to modify according to the technical evolution, without notice.
All the rights of intellectual and technological ownership are reserved



Cinisello Balsamo (MI) - Tel. 02 660621 - Fax 02 6174919 - www.etipack.it