

## System 2 twist

For top application

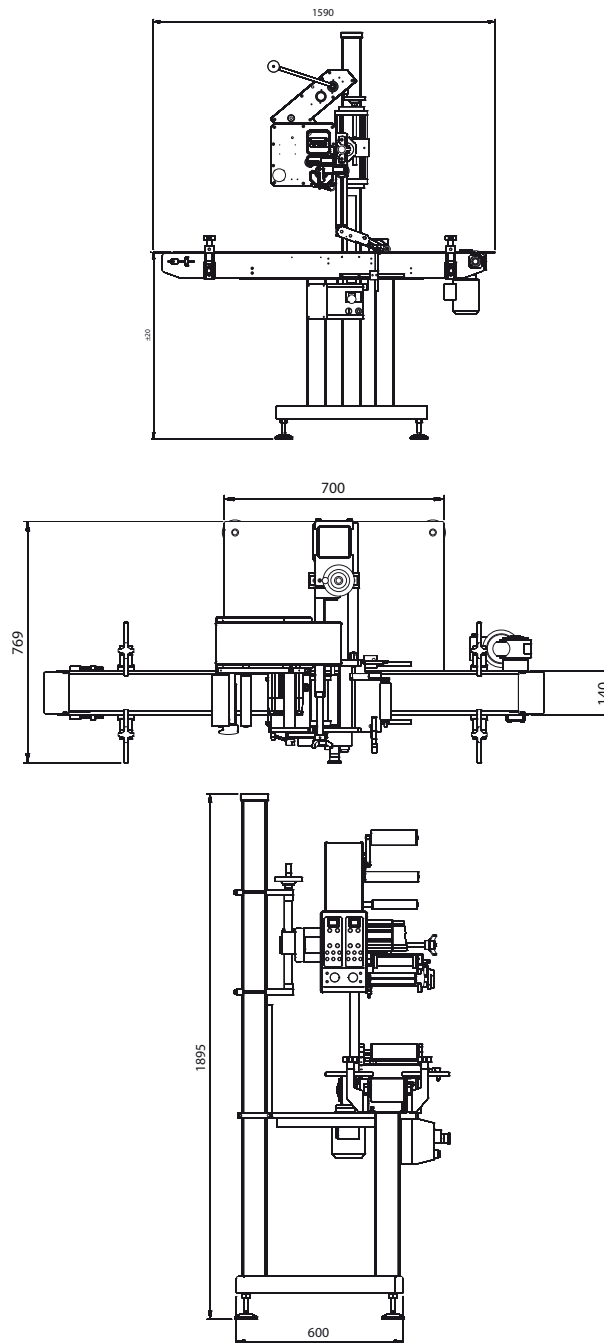

System 2 Twist applies pressure-sensitive labels on the top of every kind of products. The conveyor running at a fixed speed is the ideal solution for out-of-line applications with manual loading, while for in-line applications it can be equipped with an inverter with speed variator. Print units can be installed to print variable data, bar codes and images.



## Technical Specifications

|                       | System 2 twist         |
|-----------------------|------------------------|
| Production speed      | max 6.000 pcs./hr.     |
| Dispensing speed      | max 15 mt/min          |
| Product size Width    | From 20 x 20 mm        |
| Product size Length   | to 150 x 220 mm        |
| Label size Width      | 8 x 8 mm               |
| Label size Length     | 98 x 250 mm            |
| Outside reel diameter | 280 mm                 |
| Inside reel diameter  | 40 - 75 mm             |
| Machine size L-W-H    | 2200x1100x2100         |
| Power supply          | 230 V, 50 - 60 HZ      |
| Electrical input      | 600 W                  |
| Compressed air        | 6 bar with print units |



Etipack reserves the right to modify according to the technical evolution, without notice.  
All the rights of intellectual and technological ownership are reserved



Cinisello Balsamo (MI) - Tel. 02 660621 - Fax 02 6174919 - [www.etipack.it](http://www.etipack.it)