

System 4 Slim

For top/bottom application

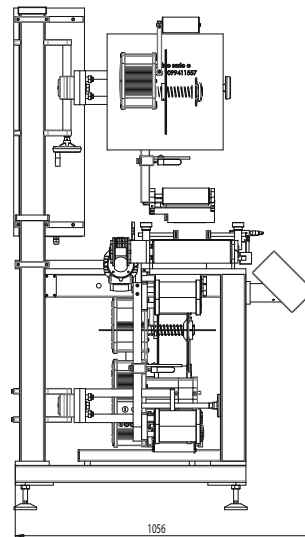
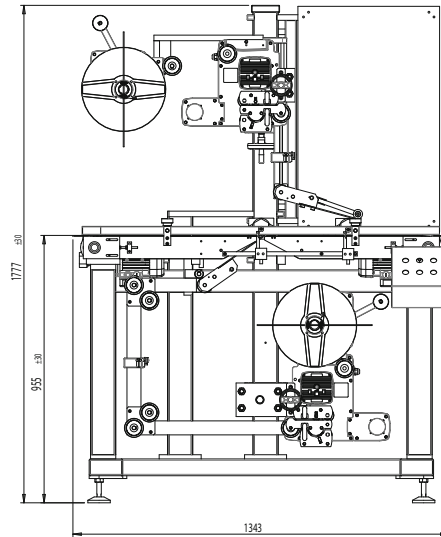

System 4 Slim is ideal to label products which cannot be conditioned by side belts, being too thin or flexible, such as the thermoformed tubs used for food packaging. To convey the product while labelling, a split-belt conveyor is used, allowing the distribution blade to emerge and apply the label on the underside of the tray.

Technical Specifications

	System 4 Slim
Production speed	≤ 20 m/min
Product size length	80 - 350 mm
Product size width	60 - 275 mm
Label size length	8 - 250 mm
Label size width	8 - 98 mm
Outside reel diameter	280 mm
Inside reel diameter	75 mm
Machine size L-W-H	1343 x 1056 x 1777 mm
Power supply	230 V, 50 - 60 HZ
Electrical input	1200 W
Compressed air	6 bar with print units



Etipack reserves the right to modify according to the technical evolution, without notice.
All the rights of intellectual and technological ownership are reserved



Cinisello Balsamo (MI) - Tel. 02 660621 - Fax 02 6174919 - www.etipack.it