

System 5 Active

For Front/Back application



System 5 Active is a labelling system designed for side labelling, including front & back, on elliptical or straight sided products. The system can be supplied with different labelling heads and can be equipped with all printing units available for printing barcodes, images and variable data.

Technical Specifications

	System 5 Active
Production speed	≤ 5.000 pcs/hr - step prod.100 mm
Dispensing speed	≤ 20 m/min
Product size length	40 - 130 mm
Product size width	28 - 90 mm
Label size length	from 8 up to 250 mm
Label size height	from 8 up to 198 mm
Outside reel diameter	280 mm
Inside reel diameter	40 - 75 mm
Machine size L-W-H	2500 x 2018 x 1542mm
Power supply	230 V, 50 - 60 HZ
Electrical input	1300 W
Compressed air	6 bar with print units

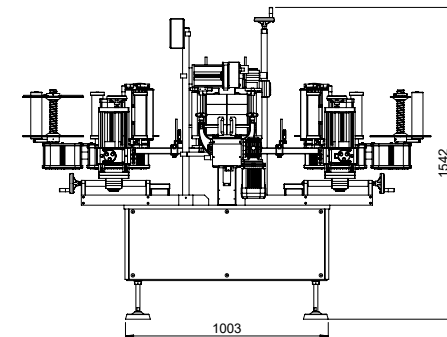
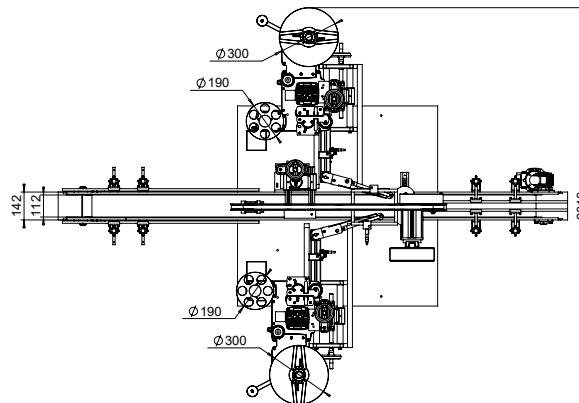
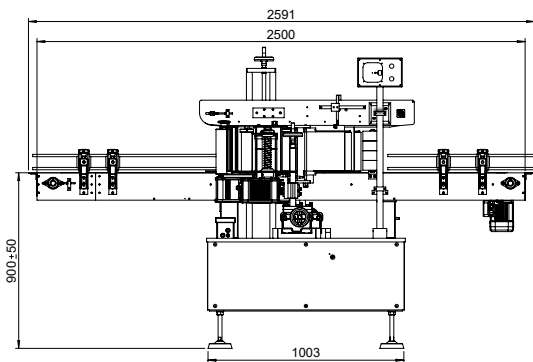

Etipack reserves the right to modify according to the technical evolution, without notice.
All the rights of intellectual and technological ownership are reserved



Cinisello Balsamo (MI) - Tel. 02 660621 - Fax 02 6174919 - www.etipack.it