

# System 9

For flat products

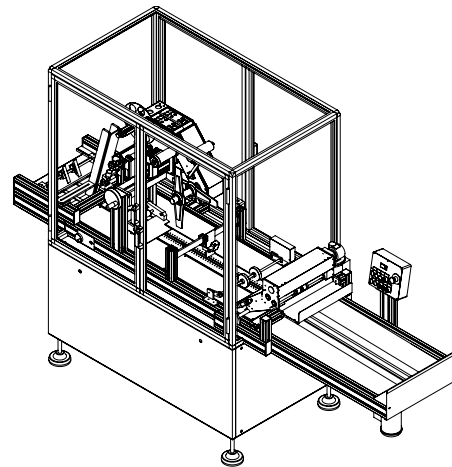

Automatic labelling system especially designed to process cards, doypack, envelopes, leaflets, flat boxes which are automatically taken from a loading stacker and conveyed horizontally by means of a vacuum conveyor system. This system is available both in the version with alternate or continuous motor and can be equipped with feeders, labellers and print units for dispensing, labelling and printing products.

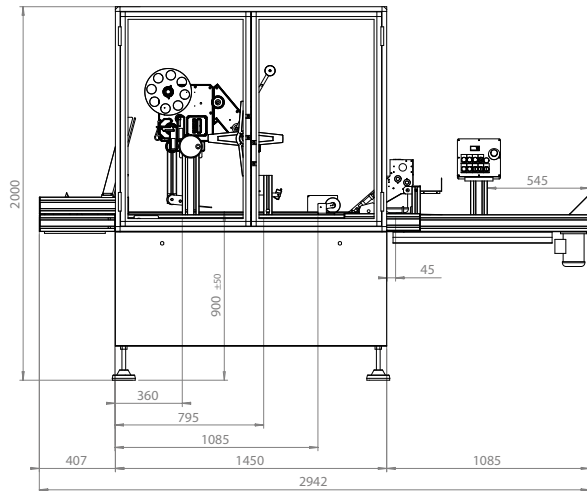

## Technical Specifications

	System 9
Production speed	max 24000 pcs/h
Product size	From 100 x 60 mm to 350 x 260 mm
Product tickness	0,5 - 5 mm
Label size (L) from	8 x 8 mm
Label size (W) to	128 x 250 mm
Outside reel diameter	280 mm, optional 380 mm
Inside reel diameter	40 - 75 mm
Machine size L-W-H	2942 x 850 x 2000 mm *(continuous movement)
Power supply	400 V, three-phase N+T
Electrical input	2000 W
Compressed air	6 bar with print unit

\*2935 x 850 x 1500 mm (alternate movement)

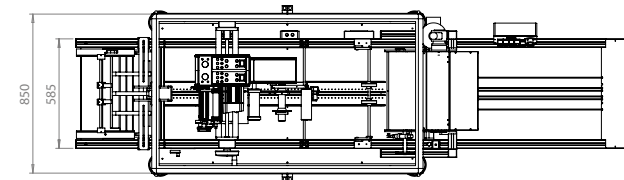

Etipack reserves the right to modify according to the technical evolution, without notice.  
All the rights of intellectual and technological ownership are reserved



Cinisello Balsamo (MI) - Tel. 02 660621 - Fax 02 6174919 - [www.etipack.it](http://www.etipack.it)