

System 9 Light

For flat products

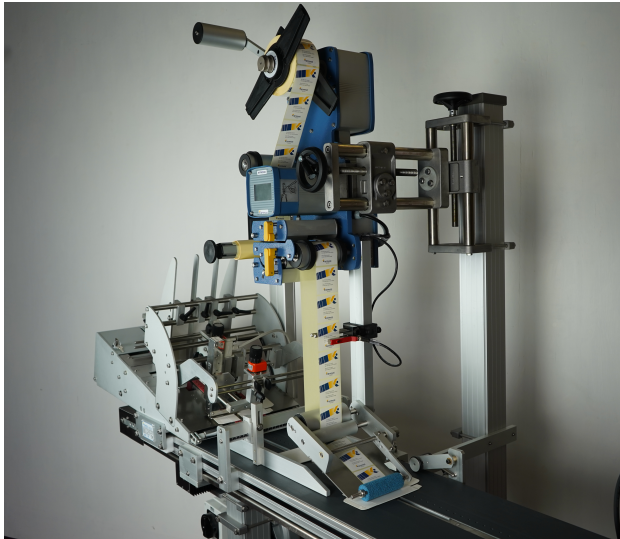

System 9 Light is a labelling system especially designed to process and label flat lying product such as envelopes, leaflets, magazines and die-cut cartons with maximum A4 size. This special configuration features the system applying radiofrequency antitheft labels within die-cut cartons.

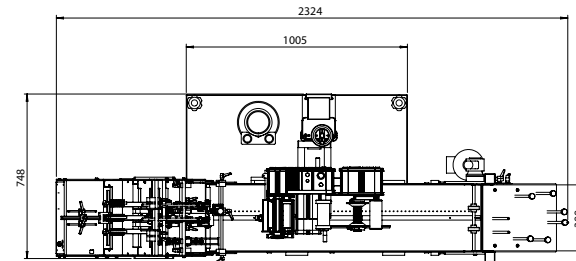
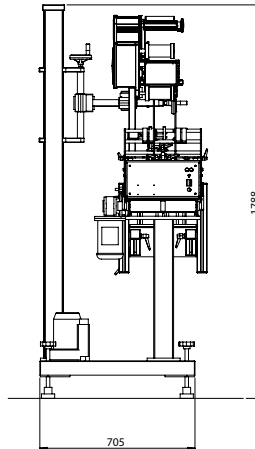
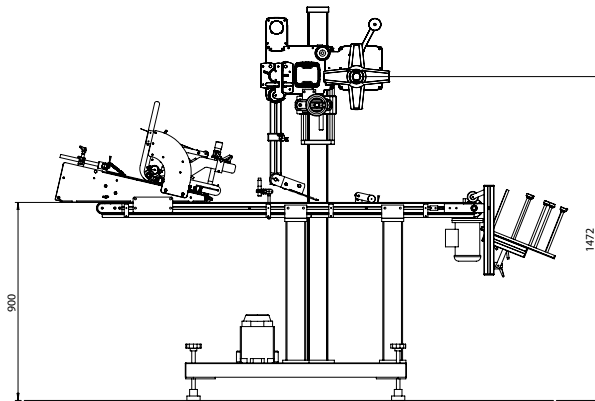

Technical Specifications

	System 9 Light
Production speed	≤ 9000* pcs/h
Product size (W x S) from	100 x 100 mm
Product size (W x S) to	290 x 290 mm
Product thickness	0,1 ÷ 25 mm
Label size (W)	8 x 8 mm
Label size (L) to	98 x 250 mm
Outside reel diameter	≤ 280 mm
Inside reel diameter	40 ÷ 75 mm
Machine size (L-W-H)	2345 x 705 x 1788mm
Power supply	400 V, 3P+N+PE 50/60 Hz
Absorption	920 W
Compressed air	6 bar with print unit

**with product step of 100 mm)*



Etipack reserves the right to modify according to the technical evolution, without notice.
All the rights of intellectual and technological ownership are reserved



Cinisello Balsamo (MI) - Tel. 02 660621 - Fax 02 6174919 - www.etipack.it